

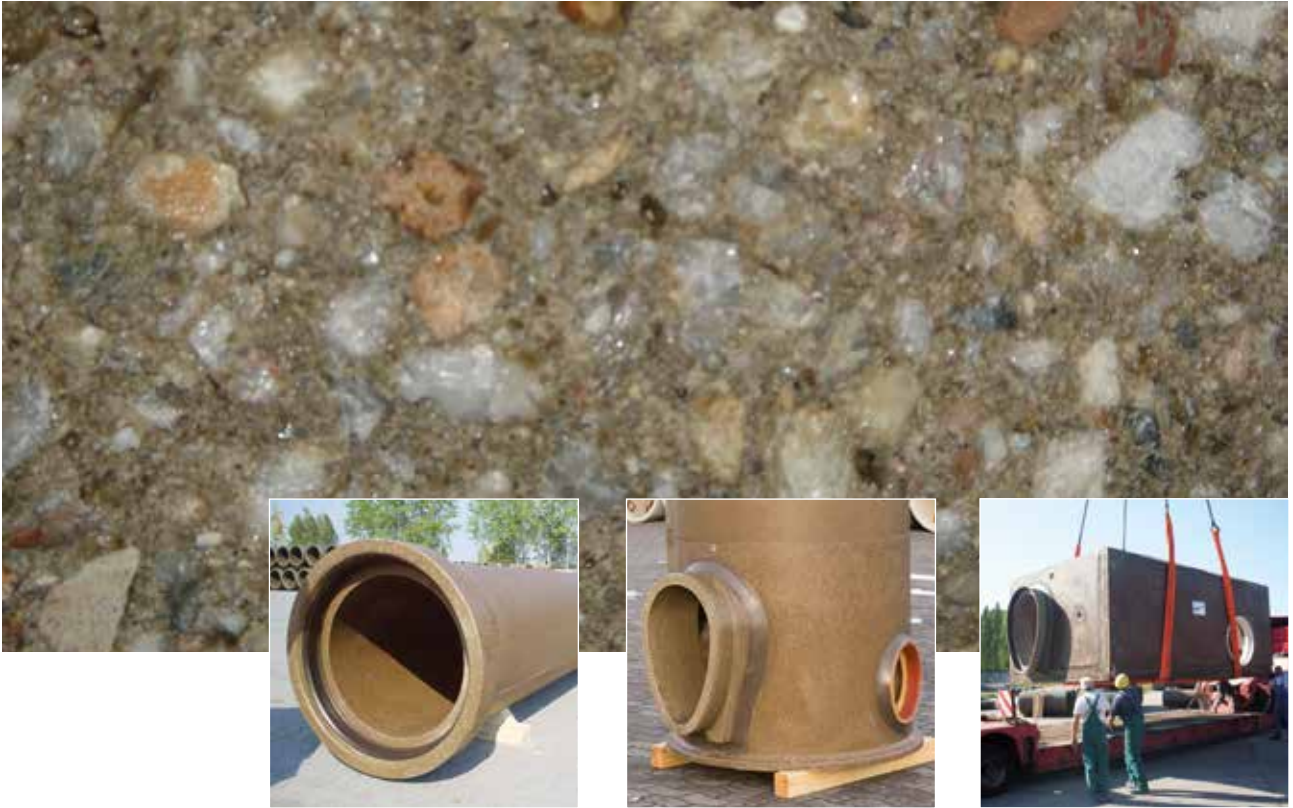

meyer-POLYCRETE®

Sewer Pipes | System Manholes | Shaft Structures

POLYCRETE® – Just the right material



POLYCRETE® sewer pipes with bell socket/rebate socket

POLYCRETE® egg-profile pipes

POLYCRETE® kite-profile pipes

POLYCRETE® system manholes

POLYCRETE® pump shafts

POLYCRETE® shaft structures

POLYCRETE® special components

POLYCRETE®- the ideal material for sewer construction

Polymer concrete material

POLYCRETE® products are made from reactive resin moulding material with filler. The customary material name is polymer concrete (or PRC for "polyester resin concrete"). The moulding material complies with DIN 16946-2, type 1140.

This combination of high quality polyester resins with pressure-resistant quartzite results in a product that combines the best features of other materials.

This sewer material ensures outstanding properties in sewer operations.

These positive characteristics in long-term practical application ensure the long service life that is essential for a cost-efficient sewer system.



Strong and durable

The close bond between resin and aggregate materials results in high abrasion resistance inside and outside and allows the reliable absorption of high compressive and bending stress (e.g. traffic loads) with small wall thickness and reduced pipe weight.

The rigid POLYCRETE® pipes are structurally stable, avoiding any height differences on the ground surface as well as any leaks due to any offset of the pipe joints.

At the same time the material is so robust and impact resistant that it is perfectly suited for practical applications on construction sites and in operation. In particular it is resistant to high-pressure cleaning, and no fragments break off when branch connection holes are drilled in a finished pipe. The smooth and even inner surface of the pipes and manholes increases the flow speed of the transported medium, which in turn reduces the formation of sludge deposits.

Material with many advantages

Due to the excellent chemical material characteristics POLYCRETE® products are well-suited for problematic situations because:

- The polyester resin is most resistant to aggressive media.
- The quartz aggregate does not suffer from chemical attack.
- The material structure is free from capillaries, does not absorb water and does not permit any gas diffusion.
- The material structure made from high quality polyester resin and pressure-resistant quartzites does not permit damage by osmosis along any fibres.

POLYCRETE® products made by meyer-POLYCRETE are therefore extremely resistant, even when exposed to aggressive soils, waste waters and gases (pH range 0.5 to 14) and can securely withstand biogenic sulphuric acid. Due to the high temperature resistance of the base material high media temperatures of up to + 85°C are possible.

Das POLYCRETE® sewer pipe



with bell socket DN 300 - DN 1000

with rebate socket DN 1200 - DN 2000

Convincing quality

Creating the best products from high quality materials. We manufacture POLYCRETE® pipes exclusively through casting, in accordance with this guiding principle. Only this way can the recipes be tailored ideally to the application and homogenous mixtures be prepared. That is because the uniform, thorough mixing process and the mixing ratio of the raw materials we use determine the long term usage characteristics of the pipes.

The direct contact of the material and the casting formwork guarantees continuous smooth and high quality surfaces over the complete length of the pipe. These surfaces are then finished with an additional coating.

At the same time this manufacturing method allows each pipe the necessary time for curing in its perfect shape in the formwork with dimensional accuracy. Thus, precise joint dimensions are assured with uniform materials and without the need to fit additional external couplings made from other materials. If the joints are not cast, as with the egg profile pipes, the factory pre-assembles couplings made from GRP - a material with almost identical chemical behaviour in soil.

The integrated joints allow the quick and secure installation of the pipes. The pipe joints for POLYCRETE® sewer pipes are designed for pipelines operated without pressure and can withstand a test pressure of up to 2.4 bar, even under draw, angular deflection and

shear loads. This also allows the use of the pipes in water protection zones.

The pipes comply with DIN 54815 as well as the international product standards EN 14636-1, ISO 18672-1 and ASTM D 6783-05. Their high quality is assured through the consistent implementation of the factory's own production monitoring and the materials testing agency of North Rhine Westphalia, MPA NRW, continuously monitors the quality in accordance with the product standards.

Fitting lengths and rocker pieces for connection to shafts are also manufactured in the necessary short lengths in accordance with customer requirements. Whether in the planning phase or in concrete installation cases - our technical department will check the suitability of POLYCRETE® sewer pipes for your particular application. Verifiable static calculations are implemented in accordance with DWA worksheet A 127. We will gladly send you our sample specifications so you can take the right materials into account in any tenders.

Feel free to request the data sheet "Load data for POLYCRETE® sewer pipes acc. to DIN EN 14636-1 and ISO 18672-1" from us.

POLYCRETE® sewer pipes with bell socket / rebate socket

POLYCRETE® sewer pipes
with bell socket
DN 300 - DN 1000

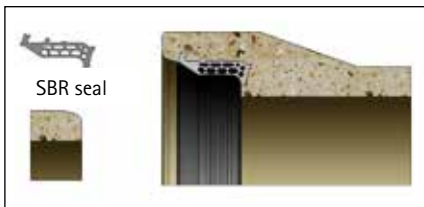
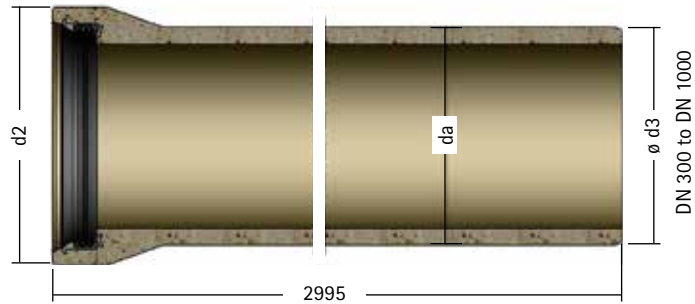

Internal diameter DN (mm)	Sleeve d2 (mm)	Pointed end d3 (mm)	External diameter da (mm)	Wall thickness s (mm)	Length L (m)	Pipe weight (kg/m)
300	382	364	366	33	3	90
400	498	480	482	41	3	145
500	614	596	598	49	3	210
600	726	708	710	55	3	280
700	835	812	830	65	3	390
800	951	928	948	74	3	500
900	1087	1064	1066	83	3	630
1000	1205	1182	1184	92	3	775

POLYCRETE® sewer pipes
with rebate socket
DN 1200 - DN 2000

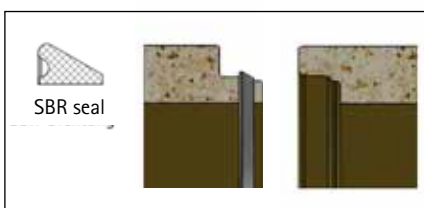
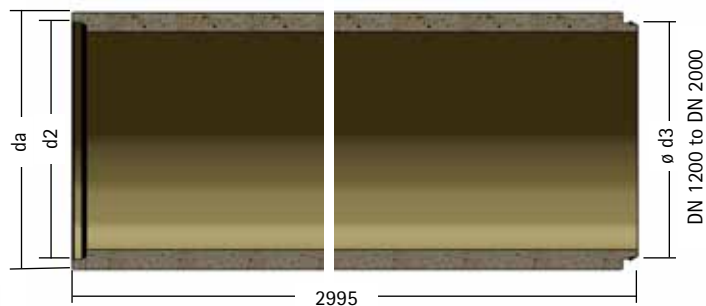

Internal diameter DN (mm)	Sleeve d2 (mm)	Pointed end d3 (mm)	External diameter da (mm)	Wall thickness s (mm)	Length L (m)	Pipe weight (kg/m)
1200	1306	1284	1420	110	3	1045
1400	1529	1501	1660	130	3	1440
1500	1632	1604	1774	137	3	1625
1600	1740	1712	1890	145	3	1835
1800	1955	1927	2120	160	3	2270
2000	2167	2136	2350	175	3	2755

POLYCRETE® egg profile pipes with GRP plug-in coupling



Egg-profile with GRP plug-in coupling

Egg profile pipes are ideally suited for the construction of mixed water sewers. Less deposited material due to the higher sweeping forces in dry weather conditions, high capacity reserve for heavy rainfall events, smaller trench width and load-bearing width as well as easier cleaning and walkability are some of their advantages. As rigid pipes with a pedestal the POLYCRETE® egg profile pipes add further convincing arguments to these positive aspects. Their high material density ensures the desired buoyancy protection, leaky pipe joints due to deformation are avoided. The pipes enable rapid construction progress as they can be laid quickly and easily on the flat, level bottom of a trench, which is easy to create. They stand securely, and the risk of insufficient compaction in the area besides the pipe foot can be disregarded as the pipes need not be "hung" in-between the manholes. The footed pipes enable thorough trench filling and compacting, and together with their bending stiffness this prevents any subsequent sagging of the road surface.

POLYCRETE® egg profile pipes offer the following advantages:

- High flow speed in dry weather conditions (partial filling) = better self-cleaning characteristics
- Greater overflow volume = better take-up and dispersal of rainwater
- Large footing curvature = more efficiency of high-pressure cleaning
- Footed pipe design = easy, cost-efficient and professional pipe-laying
- Small load-bearing width = high load-bearing capability
- Small trench width = cheaper work in confined construction sites (town centres, intersections)
- Higher profile = easy to walk

POLYCRETE[®] egg profile pipes 400/600 – 1400/2100

Y transport anchor



X GRP coupling

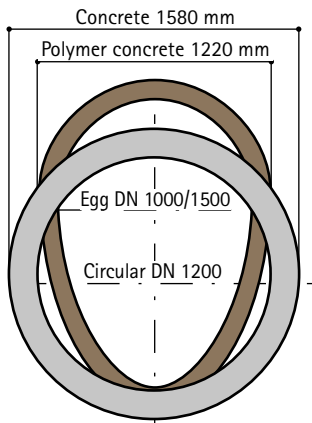
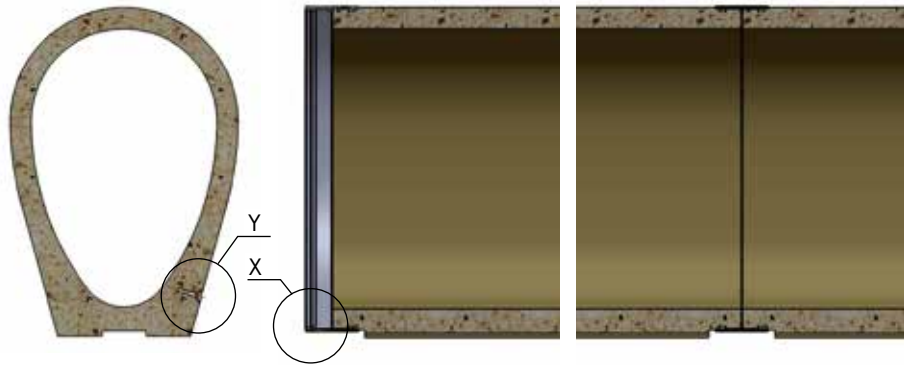
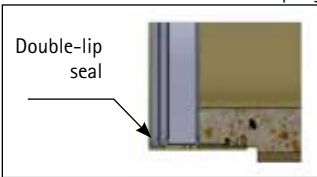

Flow-optimised egg profile for mixed water channels

Internal diameter WN/HN (mm)	External diameter d3/H (mm)	Wall thickness s (mm)	Length L (m)	Pipe weight (kg/m)
400/600	500/700	50	2.5	254
500/750	620/870	60	2.5	373
550/1000 (KL VI new)	680/1130	65	2.5	449
600/900	740/1040	70	2.5	517
700/1050	860/1210	80	2.5	682
700/1200 (KL V new)	864/1364	82	2.5	693
800/1200	980/1380	90	2	872
850/1400 (KL IV new)	1040/1590	95	2	915
1000/1500	1220/1720	110	2	1331
1050/1550 (KL III new)	1280/1780	115	2	1280
1200/1800	1460/2060	130	2	1849
1400/2100	1700/2400	150	2	2504

POLYCRETE® kite profile pipes

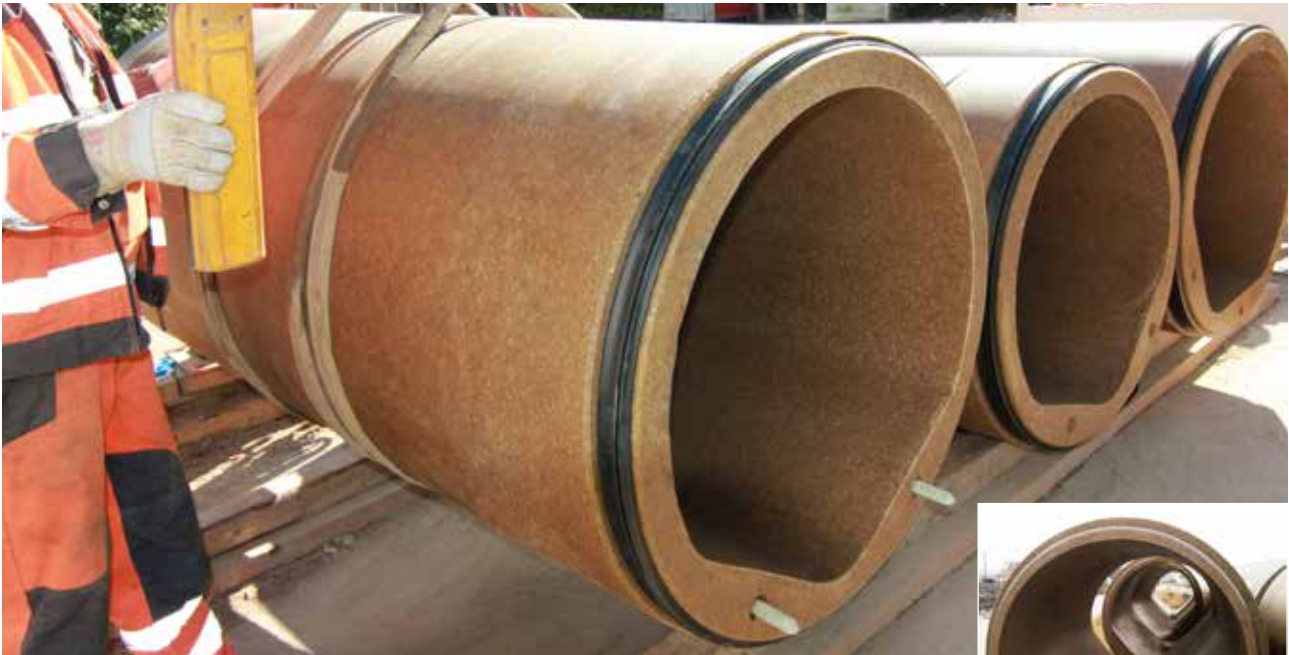

POLYCRETE® kite profile pipes

Kite profile pipes represent an improvement of flow-optimized pipe cross sections.

Through the combination of a narrow dry weather channel and a high-capacity overflow space POLYCRETE® kite profile pipes are particularly well suited for use in mixed water sewers with extreme fluctuations in waste water quantities.

The special cross-section shape with its improved hydraulic characteristics ensures the necessary flow speed and an optimised sweeping effect during dry weather while simultaneously offering adequate overflow capacity for large quantities of waste water.

The cross-section shapes of the POLYCRETE® kite profile pipes have also been designed in such a way that later on any house connections can be easily implemented. POLYCRETE® kite profile pipes are manufactured with integrated joints similar to those on round sewer pipes which assure high security and ensure easy and quick handling during installation.



POLYCRETE® kite profile pipe with rebate socket DN 2000

POLYCRETE® kite profile pipes with bell socket / rebate socket

POLYCRETE® kite profile pipes with bell sockets
DN 800 + DN 1000



Internal diameter DN (mm)	Channel radius R (mm)	Flow area av. (m ²)	External diameter da (mm)	Wall thickness s (mm)	Length L (m)	Pipe weight (kg/m)
800	150	0.48	948	74	3	520
1000	200	0.75	1184	92	3	805

POLYCRETE® kite profile pipes with rebate sockets
DN 1200 - DN 2000

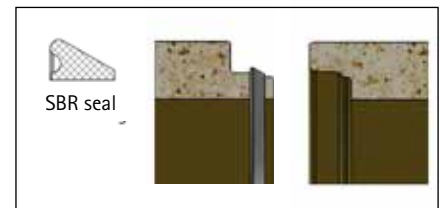

Internal diameter DN (mm)	Channel radius R (mm)	Flow area av. (m ²)	External diameter da (mm)	Wall thickness s (mm)	Length L (m)	Pipe weight (kg/m)
1200	250	1.07	1420	110	3	1180
1400	250	1.40	1660	130	3	1755
1500	375	1.60	1774	137	3	1995
1600	300	1.83	1890	145	3	2240
1800	400	2.35	2120	160	3	2710
2000	500	2.92	2350	175	3	3255

The POLYCRETE® system manhole



Sample manhole



The all-rounder

Strong enough for high dynamic loads, stable shape, suitable for high-pressure cleaning and particularly impact resistant. The POLYCRETE® manhole meets all challenges for a sewer system during installation and operation - as required in practical applications. And at the same time it has the necessary weight for the desired buoyancy protection.

The POLYCRETE® system manhole is sturdy outside and impervious to attack from inside. It features high resistance to aggressive¹⁾ and hot²⁾ media as well as to abrasion by very dirty waste water. It is smooth, non-porous, vapour-tight and joint-less up to the throat.

POLYCRETE® system manholes are individually manufactured and can thus be adapted to all connection and installation situations. They are delivered ready for installation and connection and can therefore be easily and quickly mounted.

You can connect your usual pipe system - including custom cross sections - to the POLYCRETE® manhole. Therefore POLYCRETE® system manholes are the ideal complement to any waste water pipe!

Through the use of POLYCRETE® pipes in combination with POLYCRETE® manholes you achieve a closed waste water system with consistently high quality and perfect resistance all around.

POLYCRETE® system manholes and structures are delivered with factory-installed connection pieces.

¹⁾ pH values of 0.5 to 14 possible for the media

²⁾ Temperature resistance of the base material for media temperatures of up to +85°C is possible.



POLYCRETE[®] system manholes DN 1000 - DN 2600

DN 1000 - DN 1200

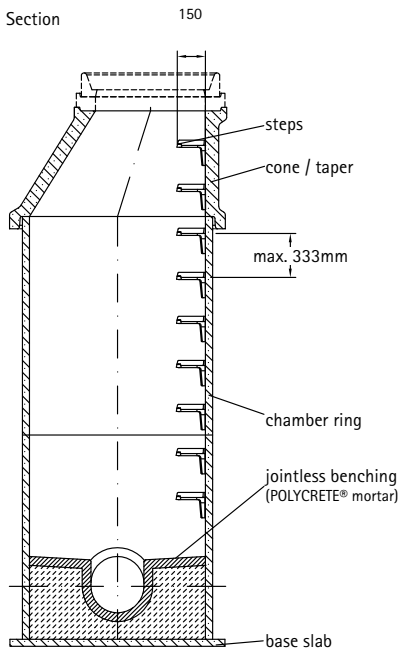

DN 1000 - DN 2600

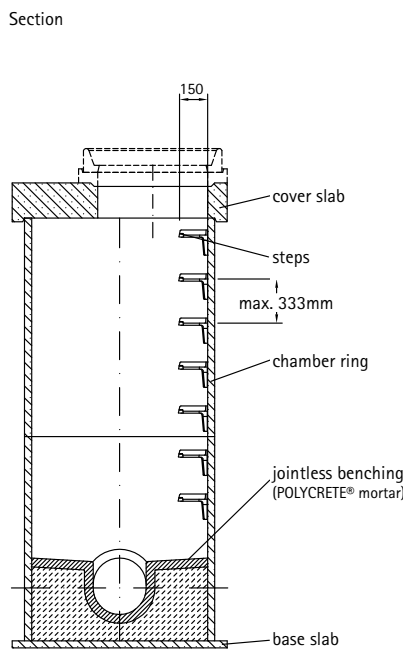

DN 1200 - DN 2600

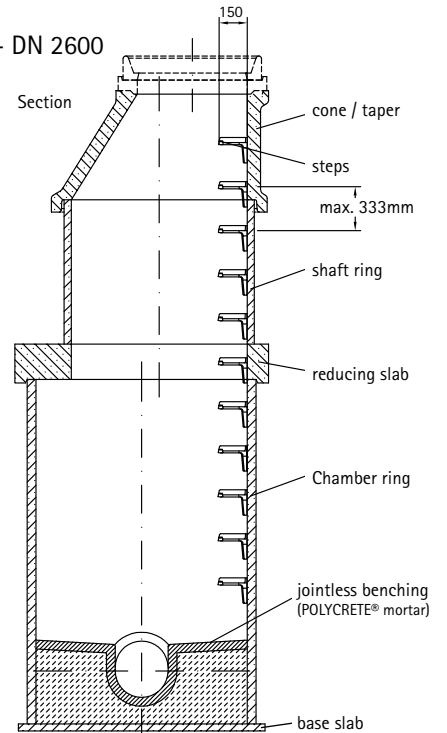

Connection variants

Integrated plug-in systems and weld systems can be delivered as connection options for vitrified clay, PVC, PP and PE-HD:

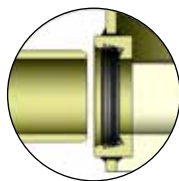

Vitrified clay GM manhole connection

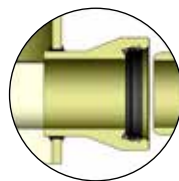

Vitrified clay GE manhole connection

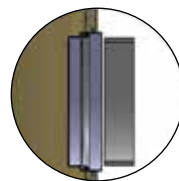

Cast-iron manhole connection

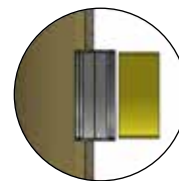

GRP manhole connection

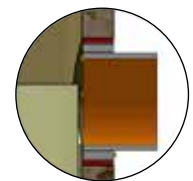

PE-HD manhole connection

Internal diameter DN (mm)	Wall thickness (mm)	Connection DN max. (mm)	Effective height		Weight Pipe (kg/m)
			min. (mm)	max. (m)	
1000	40	600	750	4.5	295
1200	50	800	950	5	435
1500	60	1000	1200	4.5	660
1600	60	1000	1200	4	705
1800	70	1200	1450	4	925
2000	90	1400	1650	5.5	1325
2200	100	1500	1750	5.5	1620
2400	140	1600	1900	8	2505
2600	175	1800	2100	10	3420

Guide values for dimensions and weights for system manholes and pump shafts

*larger effective heights are possible with custom wall thicknesses

POLYCRETE® pump shafts

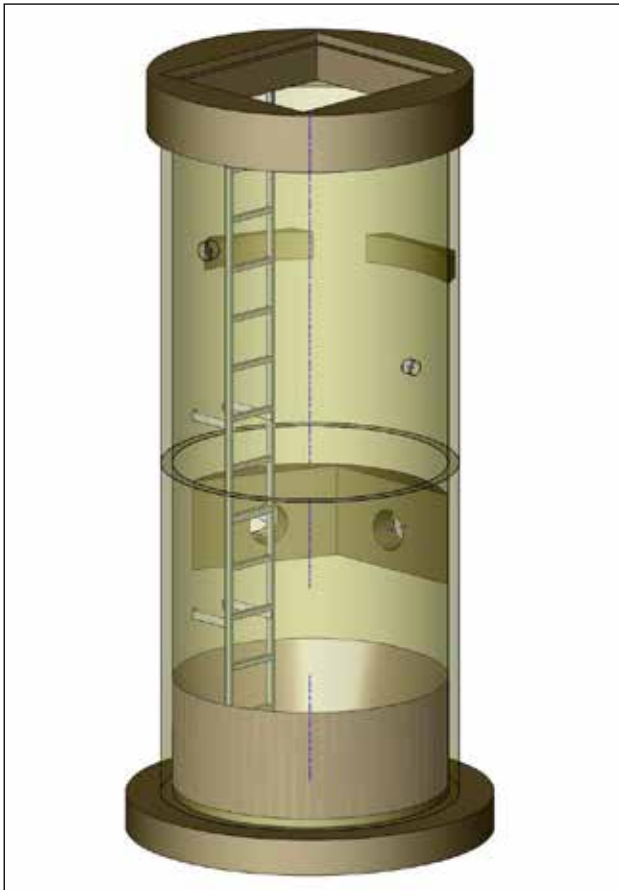

POLYCRETE® pumping station DN 1500



POLYCRETE® pumping station DN 1000 for pressure drainage

Acid does not stand a chance here

The formation of sulphuric acid by thiobacillus in waste water systems cannot always be avoided by planning. Besides the direct introduction of waste water containing sulphides, unfavourable waste water conditions such as long waste water dwelling times or insufficient oxygen supply can lead to sulphide problems. Due to the controlling framework parameters this often starts from the pump stations.

The polymer concrete material exhibits its extremely tolerance to chemicals under these aggressive environmental conditions. POLYCRETE® is most resistant to aggressive media (pH values from 1 to 12 possible) and is therefore predestined for use as a pump shaft material.

However, the special design of the POLYCRETE® pump shafts offers even more advantages. The deep installation of the shafts (caused through the creation of collection volume underneath the supply pipe level) often results in the need for expensive ground water lowering systems. Here the joint-less, mostly single-part construction of the POLYCRETE® pump shafts is worth cash money. In addition the risk of leaking at the connecting joints is eliminated. The integrated pump sump with concave moulding forms a collecting chamber without sludge deposits. Like the base plate it is made from POLYCRETE® so that the interior of the shaft is completely protected against aggressive media. Of course POLYCRETE® pump shafts are also suitable for installation as cost-efficient sunk shafts.

For guide values for the dimensions and weights for system manholes and pump shafts cf. table on page 11.

POLYCRETE® shaft structures



Individually planned and delivered ready to connect

For larger connection diameters, various different inlets and outlets and particular technical requirements the compact system manhole elements are often not sufficient. In such cases it is recommended to install POLYCRETE® shaft structures that are individually planned, designed and manufactured in close cooperation with the user for specific dimensions, loads and construction site conditions.



Oval and polygonal shaft structures are assembled in the factory in any necessary combination of prefabricated circular shell sections and flat panels made from polymer concrete. The structurally optimised designs allow a relatively thin wall thickness due to the high material strength. Thus external dimensions and weight are minimised, and even large structures can be transported and installed conveniently and at low costs.

Production in the factory is carried out under optimum conditions, independent of the weather, and ensures a consistent quality level of project-related complex engineering structures for the complete sewer system. Unsatisfactory compromises necessitated by on-site assembly are avoided, and the leak-tight connection of the POLYCRETE® shaft structure to the sewer system is assured through installation-friendly, integrated connections.



Cost, deadline and quality risks are thus avoided. The construction project is easier to calculate and almost always more cost-efficient for contractors and sewer system operators alike thanks to the quick and timely delivery of prefabricated POLYCRETE® shaft structures.

Examples of individually manufactured shaft structures

POLYCRETE® special components

Due to its remarkable material properties POLYCRETE® is also well suited for containers and pipe systems well beyond the comprehensive standard product range.

Over decades meyer-POLYCRETE has developed the production processes and know-how to manufacture challenging components from POLYCRETE®. That allows us to complement a POLYCRETE® pipe and manhole system with special components such as shaft structures, fittings (bends, branches, etc.), tangential shafts etc. to make one homogenous system. It also enables us to resolve particular challenges, be it the renovation of structures with segmented liners or furnishing existing waste water sewers with gutter channel pieces for better drainage during dry weather. But even beyond the waste water sector, e.g. in industrial systems, POLYCRETE® with its wide range of applications is well suited as an alternative for situations that would otherwise be laborious or uneconomical, or which could not be permanently resolved.

Our objective is to turn the engineering expectations of our customers into reality. Individual custom solutions are our speciality.

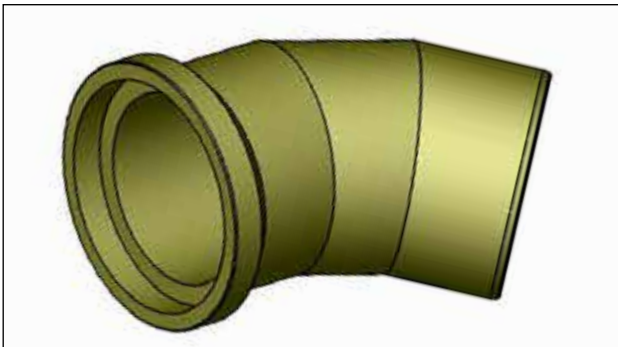

45° segmented bend - POLYCRETE® sewer pipe DN 600

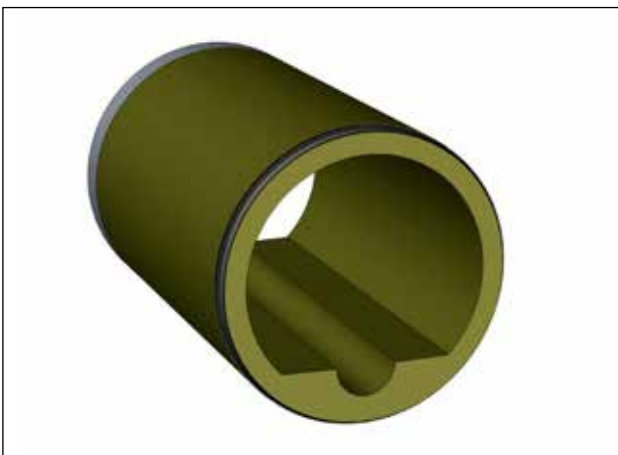

POLYCRETE® jacking pipe DN 1600 with dry weather gutter channel DN 400



Sloped piece 1:1 for crossing under railway tracks made from POLYCRETE® jacking pipe DN 1800



POLYCRETE® segment liner WN/HN 2550/1830 for cladding a collector, with integrated pipe for a creek



POLYCRETE® bend element for cladding a collector

Straight to the point



POLYCRETE® pipes, manholes and shafts from meyer-POLYCRETE offer:

- High load bearing capacity
 - Permanent security in numerous applications
- Impact resistant, highly stress-resistant material
 - Able to accept high dynamic loads, resistant to high-pressure cleaning, trouble-free boring of connections
- Dimensional stability, extremely tight dimensional tolerances
 - Leak-tight connections, no ovality, no foot offset
- Integrated or factory-fitted pipe connections
 - Simple installation, reliable sealing
- Low weight = easier handling
- High corrosion resistance, good resistance to chemicals
 - Reliable long-term operation
- Material structure made from high quality polyester resin and pressure-resistant quartzites:
 - Does not permit damage through osmosis along fibres
- High temperature resistance up to a media temperature of 85°C
- Smooth, uniform, non-porous surfaces
 - High flow speed with reduced sludge deposits
- High material density
 - Ensures the desired buoyancy protection
- Smooth, joint-free, non-porous and vapour-proof surfaces
 - POLYCRETE® system manholes
- Individual planning and manufacturing
 - Can be adapted to a great variety of connection and installation situations
- Delivered ready for installation and connection
 - Quickly and easily fitted, can be installed regardless of weather
- Long-term reliability and efficiency in use
 - Maintenance-friendly and durable
- Recyclable material
 - Re-utilisable, e.g. as broken mineral mixture
- Complete system
 - POLYCRETE® sewer pipes, POLYCRETE® system manholes and POLYCRETE® shaft structures in consistently high quality, from a single source

The content of this brochure has been carefully checked.

However, meyer-POLYCRETE and its affiliates decline any liability for problems arising from errors in this publication.

Customers should therefore contact meyer-POLYCRETE directly in order to check the suitability of POLYCRETE® products for their respective projects prior to use.

Sales:

The logo for meyer-POLYCRETE features the word "meyer" in a lowercase, rounded, sans-serif font. To its right, the word "POLYCRETE" is written in a bold, uppercase, sans-serif font, enclosed within a dark green rounded rectangular border that has a slight 3D effect.

meyer-POLYCRETE GmbH
Hoher Weg 7
D-39576 Stendal
Tel. +49 (0) 39 31 67 29 - 0
Fax +49 (0) 39 31 67 29 - 30
info@meyer-polycrete.com
www.meyer-polycrete.com